

# TECHNICAL DATA

COMBINATION ROLLER

BW 154 ACP-5, BW 174 ACP-5

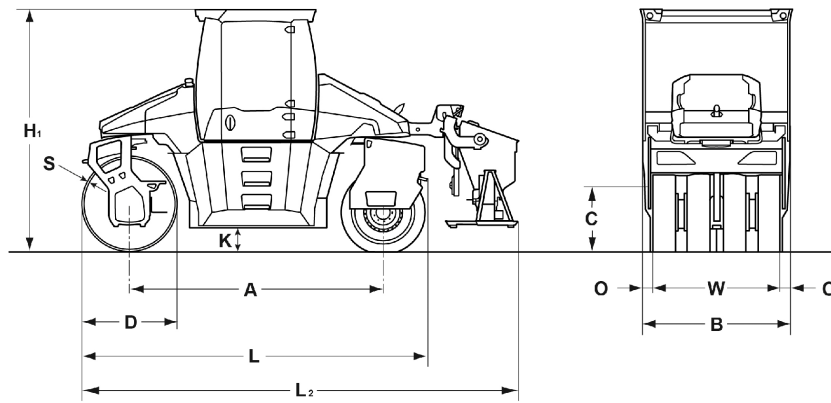



**Dimensions in mm**

	<b>A</b>	<b>B</b>	<b>C</b>	<b>D</b>	<b>H1</b>	<b>K</b>	<b>L</b>	<b>L2</b>	<b>O</b>	<b>S</b>	<b>W</b>
<b>BW 154 ACP-5</b>	2890	1680	790	1100	3020	260	3990	5030	90	16	1500
<b>BW 174 ACP-5</b>	3220	1860	810	1200	3050	280	4420	5520	90	18	1680

**Shipping dimensions in m3**

**BW 154 ACP-5**  
**BW 174 ACP-5**

**with cabin**

20,244  
 25,075

<b>Machine type</b>	<b>Compaction output (t/h) at different asphalt layer thicknesses</b>		
	<b>2-4 cm</b>	<b>6-8 cm</b>	<b>10-14 cm</b>
BW 154 ACP-5	30-55	60-120	80-150

**Technical Data****BOMAG  
BW 154 ACP-5****BOMAG  
BW 174 ACP-5****Weights**

Operating weight CECE w. ROPS-cabin .....	kg	7.400	9.000
Static linear load CECE .....	kg/cm	25,7	28,0
Axle load, drum CECE .....	kg	3.850	4.700
Axle load, wheels CECE .....	kg	3.550	4.300
Wheel load CECE .....	kg	875	1.075
Max. weight .....	kg	10.500	12.500

**Dimensions**

Track radius, inner .....	mm	2.950	2.970
---------------------------	----	-------	-------

**Driving Characteristics**

Speed .....	km/h	0- 11,0	0- 11,0
-------------	------	---------	---------

**Drive**

Engine manufacturer .....		Kubota	Deutz
Type .....		V3307 -T	TCD 3.6
Emission stage .....		Stage V / TIER4f	Stage V / TIER4f
Exhaust gas aftertreatment .....		DOC+DPF	DPF+SCR
Cooling .....		Liquid	Liquid
Number of cylinders .....		4	4
Performance ISO 14396 .....	kW	55,4	74,4
Performance SAE J 1995 .....	hp	74,2	99,6
Speed .....	min-1	2.400	2.200

**Drums and Tyres**

Drum width .....	mm	1.500	1.680
Number of tyres .....		4	4
Split drum .....		front	front

**Brakes**

Service brake .....		hydrost.	hydrost.
Parking brake .....		mech.	mech.

**Steering**

Steering system .....		2-p. pivoted	2-p. pivoted
Lateral displacement right/left .....	mm	1.130	1.360

**Exciter system**

Construction .....		radial	radial
Autom. vibr. shut off .....		standard	standard
Amplitude .....	mm	0,73/0,41	0,62/0,35
Frequency .....	Hz	44/60	44/60
Centrifugal force .....	kN	89/85	89/85

**Capacities**

Fuel .....	l	180,0	180,0
Water .....	l	550,0	680,0
Emulsion .....	l	32,0	32,0

Technical modifications reserved. Machines may be shown with options.

### Standard Equipment

- ECOMODE
- 10" Touchscreen
- Water-saving pressure sprinklers
- Pressure sprinkler system Emulsion
- Individual vibration control
- 2 amplitudes / 2 frequencies
- Autom. vibration operation
- 2 spring-loaded hinged scrapers
- Indicator and hazard lights
- ROPS cabin with seat belts  
+ heating
- 2 Outside mirrors
- Steering method/Operator's seat sliding /  
rotatable (270°)
- Steering with comfort control  
- 5 Steering modes
- Back-up alarm
- Emergency STOP
- Brake release device
- Split drums

### Optional Equipment

- ECONOMIZER
- Edge cutter
- Rotary beacon
- Special paint
- Environmentally compliant hydraulic oil
- Tool kit
- Precision spreader
- Precision spreader laterally slidable
- Automatic air conditioning
- Thermal aprons
- Radio/Radio preparation
- LED lighting package
  - additional lateral lighting for cabin
  - Follow-me-home function
  - Lighting for drum edge
  - 2x 12V sockets in supports
- Backup warning buzzer with broadband  
technology
- Additional outside mirrors
- Air-suspended comfort seat
- BOMAG TELEMATIC POWER
- BOMAG ECOSTOP
- BOMAP compaction navigation with GPS
- JOBLINK measuring technology interface
- BOMAP GPS antenna set
- BOMAP GPS antenna holder

